

# SILENT KNIGHT MODEL 5107 FIRE CONTROL/COMMUNICATOR

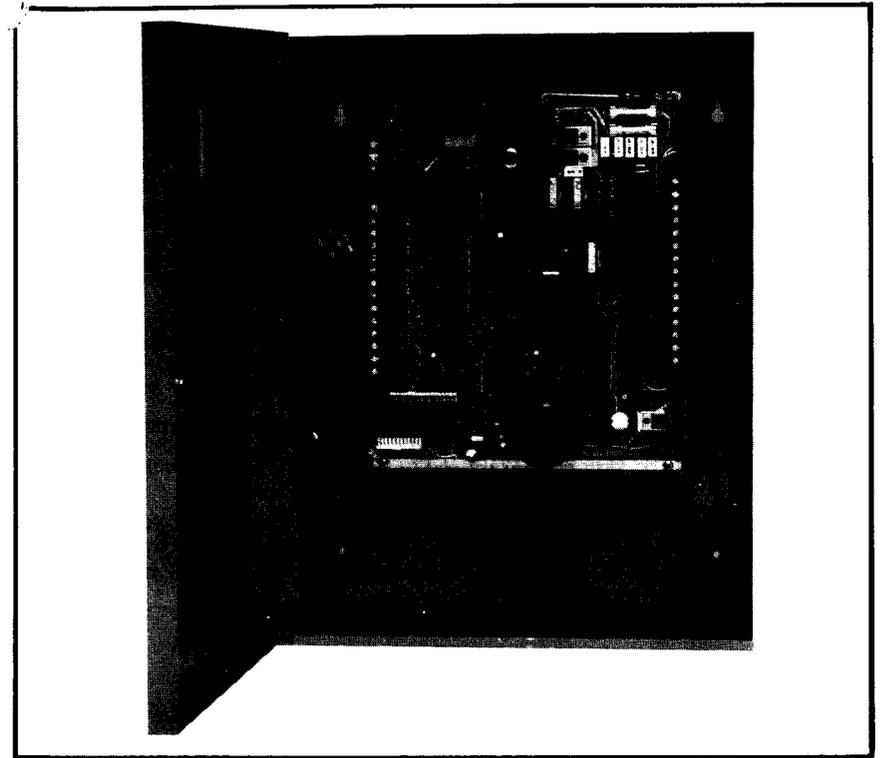

## INSTALLATION MANUAL

**SILENT KNIGHT**  
SECURITY SYSTEMS  
DIVISION OF WAYCROSSE, INC.



1700 FREEWAY BLVD. NORTH  
MINNEAPOLIS, MN 55430  
TELEPHONE: 612/566/0510

TABLE OF CONTENTS

INTRODUCTION.....1

TELEPHONE REQUIREMENTS.....1

FCC REQUIREMENTS.....1

UL REQUIREMENTS.....2

FEATURES.....2

MODEL 5107 CONTROL PANEL DESCRIPTION.....2

    PRINTED CIRCUIT BOARD.....2

    AC POWER TRANSFORMER.....2

    BATTERY CABLES.....4

    POWER LIGHT.....4

    AUDIBLE TROUBLE SIGNAL SILENCED LIGHT.....4

    FIRE RESET/AUDIBLE TROUBLE SIGNAL SPEAKER SWITCH.....4

    FUSES.....4

    EEPROM.....4

    DIALER TEST SWITCH.....4

    JUMPER WIRES.....5

    PLUG-ON CONNECTORS.....5

DESCRIPTIONS OF FEATURES.....5

    CLASS A FIRE LOOP.....5

    CLASS B FIRE LOOP.....5

    PHONE LINE MONITORS.....6

    AUTOMATIC SELF TEST.....6

    ADDITIONAL TROUBLE REPORTING.....6

    WATCH-DOG CIRCUIT.....6

MODEL 5107 REPORTING FORMATS.....6

    SILENT KNIGHT FSK FORMAT.....7

    RADIONICS HEX FORMAT.....8

PROGRAMMING.....9

    PROM REMOVAL.....9

    PROM INSERTION.....9

    SETTING THE SELF TEST TIME USING THE 5106.....10

CONTROL PANEL INSTALLATION.....10

    SELECT A LOCATION.....10

    MOUNT THE 5107.....10

    INSTALL THE 9220 POWER TRANSFORMER.....10

    CONNECT ALL INITIATING DEVICES AND ACCESSORIES.....11

    CONNECT POWER TO THE 5107.....11

ZONE WIRING.....13

**IMPORTANT:** Silent Knight products should be tested every month (under no circumstances less than every three months) to insure complete and proper operation and proper input and output connections.

**LIMITED WARRANTY**

Silent Knight Security Systems warrants that the products of its manufacture shall be free from defects in materials or workmanship for one year from the date of invoice if such goods have been properly installed, are subject to normal proper use, and have not been modified in any manner whatsoever. Upon return of the defective product to the nearest Silent Knight dealer, Silent Knight will, at its sole discretion, either repair or replace, at no cost to the customer, such goods as may be of defective material or workmanship. Customers outside the United States are to return products to their distributor for repair.

SILENT KNIGHT SECURITY SYSTEMS SHALL NOT UNDER ANY CIRCUMSTANCES BE LIABLE FOR ANY INCIDENTAL OR CONSEQUENTIAL DAMAGES ARISING FROM LOSS OF PROPERTY OR OTHER DAMAGE OR LOSSES OWING TO THE FAILURE OF SILENT KNIGHT SECURITY SYSTEMS PRODUCTS BEYOND THE COST OF REPAIR OR REPLACEMENT OF ANY DEFECTIVE PRODUCTS.

SILENT KNIGHT SECURITY SYSTEMS MAKES NO WARRANTY OF FITNESS OR MERCHANTABILITY AND NO OTHER WARRANTY, ORAL OR WRITTEN, EXPRESS OR IMPLIED, BEYOND THE ONE YEAR WARRANTY EXPRESSLY SPECIFIED HEREIN.

MODEL 7620 SMOKE DETECTOR.....	13
CLASS A ZONES.....	13
CLASS B ZONES.....	14
TELEPHONE WIRING.....	14
DUAL TELEPHONE LINES.....	14
ACCESSORY WIRING.....	15
SUPPLEMENTARY ALARM BELL.....	16
CONNECTION TO THE MODEL 7171 4-WIRE-LOOP MODULE.....	16
WIRING DIAGRAM.....	17
TERMINAL STRIP DESCRIPTION.....	18
TRANSIENT VOLTAGE PROTECTION.....	19
EARTH GROUND.....	19
5107 EARTH GROUND CONNECTIONS.....	19
MODEL 5107 UL INSTALLATION ADDENDUM.....	20

LIST OF ILLUSTRATIONS

FIGURE 1 - 5107 PRINTED CIRCUIT BOARD.....	3
FIGURE 2 - CLASS A & B TYPE FIRE LOOPS.....	6
FIGURE 3 - MODEL 7890 TRANSIENT PROTECTION.....	12
FIGURE 3A - MAIN POWER SUPPLY CONNECTIONS.....	3A
FIGURE 4 - MODEL 7620 UL LISTED SMOKE DETECTOR.....	13
FIGURE 5 - SAMPLE CLASS A WIRING DIAGRAM.....	13
FIGURE 6 - SAMPLE CLASS B WIRING DIAGRAM.....	14
FIGURE 7 - TELEPHONE LINE WIRING.....	15
FIGURE 8 - SUPPLEMENTARY ALARM BELL WIRING.....	16
FIGURE 9 - MODEL 7171 TO 5107 WIRING DIAGRAM.....	16
FIGURE 10 - MODEL 5107 WIRING DIAGRAM.....	17

INTRODUCTION

The Silent Knight model 5107 is a UL Listed combination Control/Communicator for use in a Central Station fire alarm system which features 8 supervised 24 hour fire loops and provides central station reporting over either or both of two phone lines, each with its own monitor circuit. Telephone and option information is stored in an electrically erasable PROM (EEPROM), which prevents the loss of this information upon the removal of all power and allows reprogramming up to 1000 times.

The 5107 is housed in a sturdy steel cabinet with a locking hinged cover. The 5107 also includes a UL listed Class II transformer (Model 9220), one EEPROM, six EOL resistors (Model 7630) and an AC Surge Suppressor (Model 7890).

TELEPHONE REQUIREMENTS

1. Before connecting this device to the phone lines the telephone company must be notified and provided with the following information:

- A. Manufacturer - Silent Knight
- B. Model Number - 5107
- C. FCC registration number - AC 698R-68913-AL-E
- D. Type of jack (to be installed by the telephone company) - RJ31X

NOTE: The telephone company must also be notified if this device is permanently disconnected.

2. This device may not be directly connected to coin telephone or party line services.

3. The telephone company under certain circumstances may temporarily discontinue services and/or make changes in its facilities and services which may affect the operation of this device; however, the telephone company is required to give adequate notice in writing of such changes or interruptions.

4. This device cannot be adjusted or repaired in the field; in case of trouble with the device notify the installing company or return to:

SILENT KNIGHT SECURITY SYSTEMS  
1700 Freeway Blvd. N.  
Minneapolis, MN. 55430

F.C.C. REQUIREMENTS

**WARNING:** This equipment generates and uses radio frequency energy and if not called and used in strict accordance with this manual, may cause harmful interference to radio communications. It has been tested and found to comply with the limits for a class A computing device pursuant to Subpart J of Part 15 of FCC Rules, which are designed to provide reasonable protection against such interference when operated in a commercial environment. Operation of this equipment in a residential area is likely to cause interference in which case the user will be required, at his own expense, to take whatever measures may be required to correct the interference.

## UL REQUIREMENTS (PENDING)

The 5107 is U.L. listed as a Control Unit for use in Central Station Fire-Protective Signaling Systems. If the 5107 is to be used as part of a U.L. certified system then read carefully the Model 5107 U.L. installation addendum and pay special attention to the U.L. requirements listed in this manual. The applicable standard is:

NFPA 71 - Central Station Signaling Systems

## FEATURES

- \* 2 Class A Fire Loops and 6 Class B loops.
- \* Detection of ground faults and opens.
- \* Dual phone line monitor circuits.
- \* Automatic daily test (programmable).
- \* Built in automatic battery charger circuit.
- \* Built in audible trouble signal speaker and external bell driver.
- \* Loss of AC and low battery reporting.
- \* EEPROM for programming options (non-volatile).
- \* 2 built in dual line seizure circuits.
- \* Silence audible trouble switch.
- \* Rotary or touch tone dialing.
- \* 3 reporting formats available.
- \* 2 account codes and 2 phone numbers (programmable).
- \* Restore reporting.

## MODEL 5107 CONTROL PANEL DESCRIPTION

### PRINTED CIRCUIT BOARD

The drawing in figure 1 illustrates the Model 5107 P.C. Board. This circuit board contains all the switches, jumpers, fuses and indicators that are needed to set up, monitor, reset and test the system. These major components are described in the following paragraphs.

### A.C. POWER TRANSFORMER

An external transformer (Model 9220 included) is used to supply 16.5 VAC (45VA) to power the system under normal conditions and to supply charging current to the backup battery. The primary of this transformer is connected to 120 VAC as shown in Figure A, and the secondary is wired into terminals 1 and 2 of the 5107.

### DIALER FAILED LIGHT

The red Dialer Failed Light is normally off and will come on after the communicator has failed to make contact with the central station receiver within the programmed number of attempts. See Figure 1.

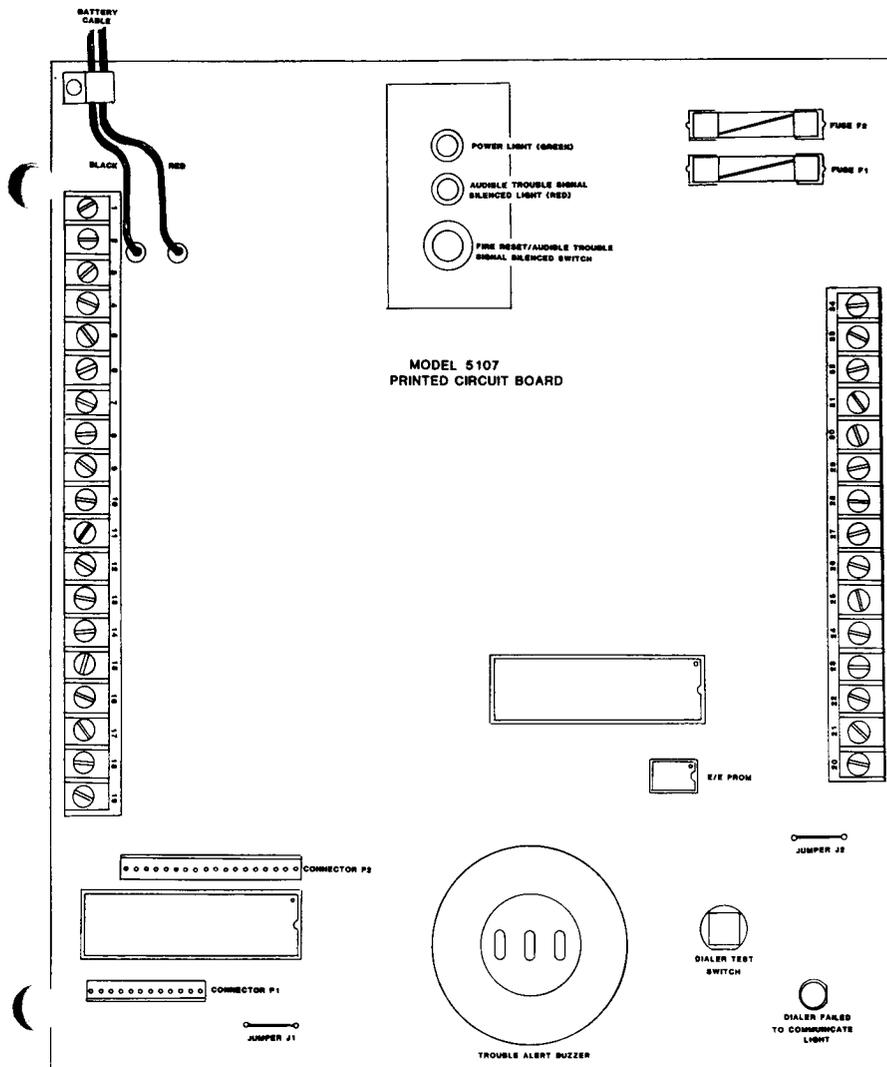
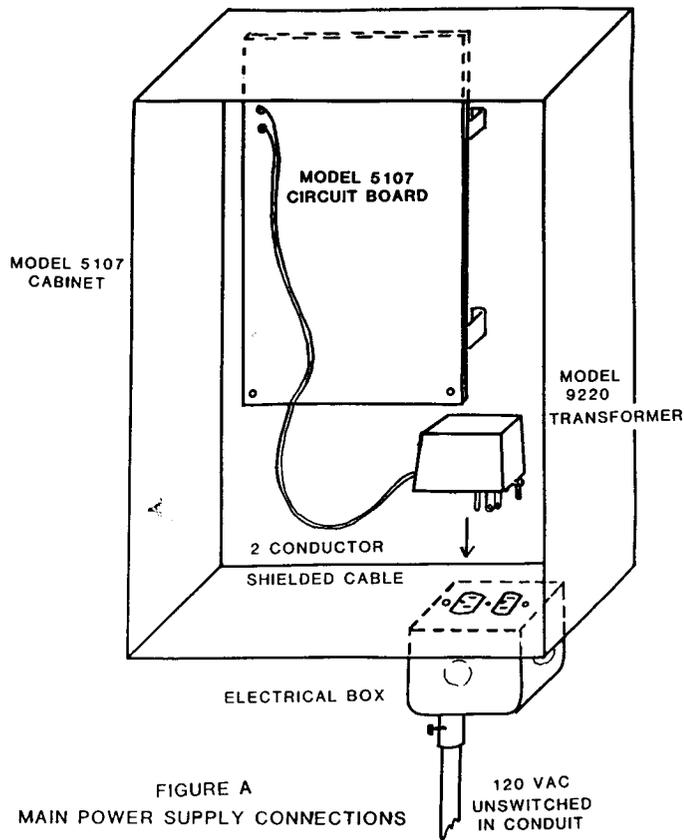

FIGURE 1



#### BATTERY CABLES

The RED (+) and BLACK (-) battery cables are used for connection to a 6-AH 12V battery (Silent Knight Model 6816) which will provide a min. of 24

hours backup power to the 5107 in the event of AC power interruptions.  
**CAUTION:** To prevent damage to the 5107 observe proper polarity when connecting the battery cables.

**NOTE:** The Model 6816 12V 6-AH battery provides over 24 hours of standby operation to the basic 5107 system. The use of accessories may reduce the standby time so that additional battery capacity may be needed to meet the 24 hour UL requirement.

#### POWER LIGHT

The green power light is normally on and will remain on unless one or more of the following conditions occur:

- \* AC power is removed from the 5107.
- \* Fuse F2 is open
- \* The Fire Reset switch is being pressed.

#### AUDIBLE TROUBLE SIGNAL SILENCED LIGHT

The red Audible Trouble Signal Silenced Light is normally off and will remain off unless the Audible Trouble Signal has been silenced by the Audible Trouble Signal Speaker Switch. Once this light is on, it will remain on until the trouble has been resolved.

#### FIRE RESET/AUDIBLE TROUBLE SIGNAL SPEAKER SWITCH

This switch has two functions. One is to silence the Audible Trouble Signal which will sound if one or more of the supervised loops becomes defective. When you do this the red "Audible Trouble Signal Silenced Light" is turned on and remains on until the trouble is resolved. The other function of this switch is Fire Reset, which momentarily removes power from terminal 34 which will reset the smoke detectors.

#### FUSES

F1 is a 1-1/2 Amp Slow Blow Fuse which provides over-current protection for any accessories connected to terminal 33 of the 5107. F2 is a 1/2 Amp Slow Blow Fuse which provides over-current protection for the smoke detectors and any other accessories attached to terminal 34 of the 5107.

#### EEPROM (Electrically Erasable Programmable Read Only Memory)

The 5107 uses an EEPROM to store specific options such as telephone numbers, reporting format, account numbers etc.. These options must be programmed into the EEPROM by using either the Model 5506 Desk Top Programmer or the Model 5510 Handheld Programmer. Refer to the programming section for more information.

#### DIALER TEST SWITCH

By depressing this switch the 5107 will automatically dial the Central Station and report a test code.

## JUMPER WIRE

Refer to Figure 1 for the locations of the following jumpers.

- J1 -** Ground Fault Detection Jumper: This jumper is left in place to enable the 5107 to detect ground faults in the Class A zones. If this jumper is removed or cut the 5107 will not detect a ground fault in these zones.

## PLUG-ON CONNECTORS

Plug-on connectors P1 and P2 are used for programming the automatic self test feature (see the automatic self test paragraph). The Model 5106 Program Module will plug into these connectors. Refer to the paragraph titled "How to Set the Automatic Self Test Time" in the Programming section for details.

## DESCRIPTIONS OF FEATURES

### CLASS A FIRE LOOP

The 5107 features 2 Class A fire zones. Each Class A Fire zone is a four wire circuit which allows an alarm to be detected even after a single open or ground fault occurs (see figure 2). A single open or ground fault will cause the audible trouble signal to sound and the 5107 will report the trouble to the central station. Use only Normally Open initiating devices for these zones. The Class A zones are zones 1 and 2. Additional Class A zones may be formed by adding model 7171 Class A Loop Monitors to Class B zones as shown in Figure 10. Any Class B zone input of the 5107 may be used. All wiring between the 7171 modules and the 5107 should be enclosed in conduit.

### CLASS B FIRE LOOP

Zones 3 through 8 on the 5107 are Class B Fire Zones. Each Class B zone consists of a two wire circuit which will detect the occurrence of an open in the loop but may not be able to detect an alarm after such an occurrence (see figure 2). The detection of an open will cause the audible trouble signal to sound and the 5107 will report the trouble to the central station. Use only Normally Open initiating devices for these zones.

**NOTE:** For the purpose of this manual, a normally open device is one whose contacts conduct when in the alarm condition and do not conduct in the non-alarm condition.

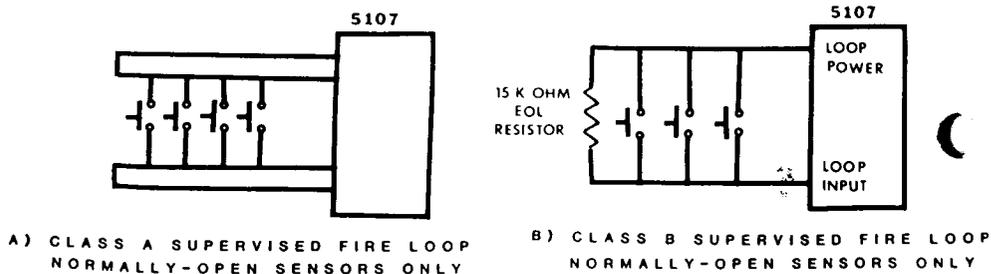

## PHONE LINE MONITORS

The 5107 has built-in dual phone line monitors. These circuits will detect any fault in the phone lines by monitoring their voltages. They feature a delay of approximately 45 seconds before a line fault is reported as trouble. When a fault is detected for more than this period the audible trouble signal will sound and the trouble will be reported to the central station over the remaining functional phone line.

## AUTOMATIC SELF TEST

The built-in self test circuit provides for automatic daily testing (at a predetermined time) of the communications links between the 5107 and the central station. The Silent Knight Model 5106 Program Module plugs into the 5107 circuit board and is used to set the correct time and the auto test time. The 5107 clock circuit is crystal controlled and maintained even if AC power is interrupted. The self test can also be manually initiated at any time by depressing the Dialer Test switch. Depressing this switch will cause the 5107 to report a test code to the central station.

## ADDITIONAL TROUBLE REPORTING

In addition to the trouble conditions already discussed, a low battery or a loss of AC power condition will also sound the audible trouble signal and cause the 5107 to report the trouble to the central station. The backup battery of the unit are continuously being charged and monitored to insure it is in good condition. If a loss of AC is detected, it will be reported and the backup battery will supply power to the unit.

## WATCH-DOG CIRCUIT

During normal operation, the microprocessor of the 5107 is constantly running its program to check inputs and carry out other routine functions. If for some reason this program stops running, the watch-dog circuit will automatically detect this and attempt to resume normal operation by resetting the microprocessor. Each time the watch-dog circuit initiates a reset signal it will also sound the audible trouble signal for a short beep.

## MODEL 5107 REPORTING FORMATS

The 5107 can transmit information in three different formats. The format you choose depends on the type of receiver used at the central station. The three formats available are:

\* SILENT KNIGHT FSK - high speed, single round format, for use with Silent Knight Model 8510/8520 receivers.

\* RADIONICS HEX - format for use with Radionics or updated Ademco receivers.

\* EXPANDED RADIONICS HEX - format for use with Radionics receivers.

## SILENT KNIGHT FSK FORMAT

The Silent Knight FSK format transmits a four digit account number and a two digit alarm code as described on the following page.

TWO DIGIT ALARM CODE	DESCRIPTION
00	NOT USED
01-08	ZONES 1-8 RESPECTIVELY ARE IN ALARM (*1)
09-20	NOT USED
21-28	ZONES 1-8 RESPECTIVELY HAVE BEEN RESTORED TO NORMAL, FROM AN ALARM CONDITION.
29	NOT USED
30	DIALER TEST
31	PHONE LINE FAULT
32	NOT USED
33	EARTH GROUND FAULT
34	NOT USED
35	RESTORATION OF PHONE LINE FAULT
36	NOT USED
37	RESTORATION OF EARTH GROUND FAULT
38-59	NOT USED
60	LOSS OF AC (*1)
61-68	ZONES 1-8 RESPECTIVELY ARE IN TROUBLE, SUPERVISED LOOP HAS BEEN BROKEN (*1)
69	LOW BATTERY VOLTAGE (*1)
70	AC POWER RESTORED
71-78	ZONES 1-8 RESPECTIVELY HAVE BEEN RESTORED TO NORMAL, FROM A TROUBLE CONDITION.
79	BATTERY VOLTAGE RESTORED
80-99	NOT USED

\*1 - REPORT MEMORY: Report memory is an option that is selected when programming the EEPROM (see Prom Coding Form). When report memory is selected, an alarm or a trouble condition in any of the eight zones or two power sources will be remembered and re-reported along with other new conditions until they are restored. All other events are reported only once.

### RADIONICS HEX FORMAT

When using a Radionics or Ademco receiver you must select the Radionics Hex format on the Prom Coding Form. When you have selected this format, the 5107 will translate the Silent Knight two digit codes into data that these receivers will recognize. An EXPANDED HEX format option allows the use of all alarm zones when reporting to a Radionics receiver. Only the normal HEX format can be decoded by an Ademco receiver. The following chart shows what will be displayed at either receiver for each of the corresponding two digit Silent Knight codes. The Radionics receiver will display a three digit account code and an English message. The Ademco receiver displays alarms as a single digit code along with the three digit account number. All other events are displayed as 8 channels plus a status channel on the Ademco receiver.

S.K. 2-DIGIT CODE	RADIONICS RECEIVER	RADIONICS RECEIVER	ADEMCO RECEIVER
	EXPANDED HEX FORMAT	NORMAL HEX FORMAT	NORMAL HEX FORMAT CH. 1234 5678 STATUS CH.
01-08	ALARM ZONE 1-8 (respectively)	ALARM ZONE 1-5 (respectively)	1-5 (alarms are displayed as 1 digit code)
21-28	RESTORE ZONE 1-8 (respectively)	RESTORE ZONE 1-5 (respectively)	3555 5555 7 (Zone 1 restore shown)
30 TEST	RESTORE ZONE 9	RESTORE ZONE 9	5555 5555 9
31	TROUBLE ZONE B	TROUBLE ZONE 7	5555 5505 7 (trouble zone 7)
33	TROUBLE ZONE C	TROUBLE ZONE 8	5555 5550 7 (trouble zone 8)
35	RESTORE ZONE B	RESTORE ZONE 7	5555 5535 7 (restore zone 7)
37	RESTORE ZONE D	RESTORE ZONE 8	5555 5553 7 (restore zone 8)
60	TROUBLE ZONE 0	TROUBLE ZONE 6	5555 5055 7 (trouble zone 6)
61-68	TROUBLE ZONE 1-8 (respectively)	TROUBLE ZONE 1-5 (respectively)	0555 5555 7 (trouble zone 1 shown)
69	TROUBLE ZONE 9	TROUBLE ZONE 9	5555 5555 8 (low battery)
71-78	RESTORE ZONE 0	RESTORE ZONE 6	5555 5355 7 (restore zone 6)
71-78	RESTORE ZONE 1-8 (respectively)	RESTORE ZONE 1-5 (respectively)	3555 5555 5 (restore trouble Z1 shown)
79	RESTORE ZONE 9 (same as test)	RESTORE ZONE 9 (same as test)	5555 5555 9 (same as test)

## PROGRAMMING

The 5107 requires specific information and option selections which must be programmed into the EEPROM (Electrically Erasable Programmable Read Only Memory). The EEPROM is an 8-pin Integrated Circuit Chip which can be reprogrammed over and over. The Prom Coding Forms provided explain each option. Programming this information allows users to customize the 5107 to meet their needs. The Model 5506 Desk Top Programmer or the Model 5510 Hand Held Programmer can be used to program the EEPROM. Refer to the operation manual of the programmer and the Prom Coding Form to program the PROM. The 5107 is shipped with the EEPROM inserted in its socket on the printed circuit board (See Figure 1). The EEPROM must be removed and programmed before installing the 5107 Control Panel (See PROM removal below). If you wish to use the Model 5506 programmer, it must contain revision 8503-1 or later software. If you use the Model 5510 programmer, it must contain 8503-1 or later software. If your programmer contains older software, please contact the Customer Service Department to have it updated. The sockets of both programmers are designed for 16 pin IC's. It is important that the EEPROM is inserted into the correct half of the programmer socket (See figure below). Pin 1 of the PROM should be inserted in the lower left hole of the programmer socket. When using the Model 5506 programmer, always use socket #1 to prevent damage to the PROM. After the PROM has been programmed, remove it from the programmer socket and reinsert it in its socket on the 5107 PC Board (See PROM insertion below).

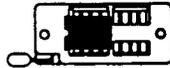

## PROM REMOVAL

To remove the EEPROM from its socket on the PC Board, carefully pull straight out on the PROM Puller (clear plastic loop). Save the PROM Puller for re-use. If the loop is missing, use a small flat-blade screwdriver to gently lever the PROM out of its socket. Slip the screwdriver under one end of the PROM and pry up slightly, then place the screwdriver under the other end and finish removal.

## PROM INSERTION

To insert the PROM back into its socket on the 5107 PC Board, place the plastic PROM Puller between the two rows of pins on the PROM and carefully press the PROM with Puller back into its socket. Pay careful attention to which way the notch cut-out of the PROM is facing. It should be on the right side if the board is oriented as shown in figure 1. Apply even pressure on each end of the PROM so that it goes in squarely.

## PROM PROGRAMMERS

### MODEL 5506

Plug in the AC power cord.  
Turn on the POWER switch.

Display shows: "HELLO".

Press "ENTER".

Display shows: 0---0

You are now in Step "0" and ready to start programming.

Step 0: Enter "5107".

Display shows: 15107

If the step number did not change to "1", then either you entered the model number incorrectly or your programmer cannot program the Model 5107. If this is the case contact the factory and we will express the correct software at no charge.

Step 1: This is an unused file location for your own use.

Example: If you wish to use this location to record the date the system was installed and today's date is 11/5/85, you would enter in Step 1 the following; 1155.

Display shows: 11155

Press "ENTER".

Display shows: 2---1

Continue programming Steps 2 through 11 using the data as entered in the PROGRAM CODING FORM for the 5107.

After completing Step 11 the display will show "05107".

You are now ready to program the PROM. Be sure there are NO PROM's in any of the sockets.

Press the "PROGRAM" key.

Display shows: "CHIP 1"

Place the handle of PROM socket "1" in the raised position.

Insert the PROM into the socket, making sure that the notch of the PROM faces toward the handle.

Close the socket by moving the handle down until it locks.

Press the "PROGRAM" key.

The display will show either "PASS" or "FAIL".

"FAIL" indicates that either the PROM was inserted incorrectly, no PROM was inserted or the PROM is defective.

**CAUTION:** Always program the PROM with the program in Step "0"

Additional PROM's may now be programmed. **NOTE:** Only the Steps that require different data from the first PROM need be changed, as all the previously programmed data is still present in the 5506 Programmer. To do this, simply press the "ENTER" key until the step is displayed that you wish to change, and then enter the new data.

**Note:** If incorrect data is programmed into the PROM or if in the future, the option requirements change, this PROM can be reprogrammed up 1000 times.

MODEL 5510

Press the "ON" key.

Display shows: "HELLO"

Press the "ENTER" key.

Display shows: 0---0

You are now in Step 0. Proceed exactly as described for the Model 5506 above.

PROM CODING FORM FOR THE MODEL 5107 CONTROL/DIALER CHIP

Programmer Requirements: Model 5506 with revision 8503-1 or later software.  
Model 5510 with revision 8503-1 or later software.

Prom Type: Electrically Erasable (8-pin) X2443 or X2444

\*\*\*\*\*

<u>STEP</u>	<u>DATA</u>	<u>DEFAULT</u>	<u>RANGE</u>	<u>DESCRIPTION</u>
0	5107			
1	---	5107	0-9999	Optional file # for your own use.
2	--	1	1-15	Number of attempts before switching phone numbers.
3	--	10	5-10	Total number of attempts to be made. (combined total)
4	--	8	1-15	Number of hours before AC Power Loss is reported.
5	--	2	1-4	Waterflow switch detection delay 1= .03 - .04 seconds 2= 3 - 4 seconds 3= 30 - 40 seconds 4= 60 - 80 seconds

**NOTE:** If switches with built in delays are used, choose a value of 2 for Step 5

There are (7) selections to be made in step 6. Circle the digits (1-8) next to the options you DO want. The programmer will display only those options that are selected (see note 3). An (N) in the Default column indicates that the option is not selected by default. A (Y) indicates that the option is selected by default.

6.1	1	N		Report restores to phone number one.
6.2	2	N		Report restores to phone number two.
6.3	3	N		Expanded Radionics Format (see note 4) (applies to both phone numbers)
6.4	4	Y		Can call phone number two.
6.5	5	Y		Must call phone number one.
6.6	6	N		Must call phone number two (also select 6.4)
6.7	7	NOT USED		
6.8	8	Y		Report memory (old events) (Applies to both phone numbers)

There are (8) selections to be made in step 7. Circle the digits (1-8) next to the options you DO want. The programmer will display only those options that are selected (see note 3).

STEP	DATA	DEFAULT	DESCRIPTION
7.1	1	N	Phone number one is touchtone. (if N then phone #1 is rotary dial)
7.2	2	N	Phone number one is 2300Hz acknowledge. (if N then phone #1 is 1400Hz acknowledge)
7.3	3	N	Phone number one is Radionics hex data. (if N then phone #1 is Silent Knight FSK)
7.4	4	N	Not used.
7.5	5	N	Phone number two is touchtone. (if N then phone #2 is rotary dial)
7.6	6	N	Phone number two is 2300Hz acknowledge. (if N then phone #2 is 1400Hz acknowledge)
7.7	7	N	Phone number two is Radionics hex data. (if N then phone #2 is Silent Knight FSK)
7.8	8	N	Not used.

Steps 8 and 9 contain the two account numbers. Only the Silent Knight format uses all four digits. The Radionics format will ignore the left hand digit. If using the Radionics format, you must enter an "A" in place of any "0's". Entering a "0" will print as a blank on the Radionics receiver.

**NOTE:** You must enter leading "0's" if the account number has less than four digits.

8	----	Account number one (for phone number one).
9	----	Account number two (for phone number two).

Steps 10 and 11 contain the two phone numbers. Each phone number can contain up to sixteen digits. Enter "A" for a two second pause. Enter "D" to look for a 2nd dial tone. The programmer will display "F" to fill any extra spaces.

10	----- ----- ----- -----	Phone number one.
11	----- ----- ----- -----	Phone number two.

IMPORTANT INFORMATION CONCERNING THE PROGRAMMING OF THE MODEL 5107 CONTROL/DIALER CHIP.

- 1) When using the Model 5506 programmer, insert the prom in socket #1. Be sure the notched end of the prom (indicating pin 1) is to the left when inserted in socket #1 of the programmer.
- 2) The DATA column of the prom coding form is where you enter or select the information to be programmed.

The DEFAULT column of the prom form shows the information that the programmer normally contains in its ROM. If you change nothing in a step, this is what will be programmed into the prom.

The RANGE column of the prom form shows the minimum and maximum possible values that may be used for that step.

- 3) When programming steps (6) and (7) be aware that the programmer can only display (4) digits at a time. In order to display all (8) digits the programmer will alternate its display between the first (4) and the last (4) digits. If you do NOT want a specific feature or option, be sure that the digit associated with that feature or option is NOT displayed.
- 4) If (N) is selected in step 6.3 and either phone number reports in the Radionics format, then zones 6, 7 and 8 CANNOT be used for alarm reporting. Instead, low AC will report as zone 6, the phone line monitors will report as zone 7, and earth ground fault will report as zone 8.

**NOTE:** You must select (N) in step 6.3 if reporting to an Ademco receiver.

If the 5107 reports to a Radionics receiver then you may select (Y) in step 6.3 and you may use all 8 zones. In this case, low AC will report as zone 0, the phone line monitors will report as zone B, and earth ground fault will report as zone C.

## HOW TO SET THE AUTOMATIC SELF TEST TIME USING THE 5106

To program the automatic self test feature of the 5107 requires the use of the Model 5106 programmer. You must set the real time and the alarm time desired with the 5106. The cables from the 5106 plug onto connectors P1 and P2 on the 5107 printed circuit board. (See Figure 1) The 5106 does not require an external power source such as a transformer or a battery. After you have plugged the 5106 into the 5107 with the connecting cables, apply power to the 5107. The display on the 5106 should light up and either the "real time" or the "alarm time" light should be lit. Select the time you wish to set by pressing the "real time" or "alarm time" switch. To set the time, press the "fast set" switch until the display reads close to the time desired. Then set the exact time using the "slow set" switch. Make sure you pay attention to the "AM" indicator to the left of the display. When it is lit, the time is AM. If when setting either the real time or alarm time, the two times are the same, the control panel will report a test. When you are finished programming, unplug the two cables from the 5107. The control panel will now report a test every day at the alarm time selected.

## 5107 CONTROL PANEL INSTALLATION

### 1. SELECT A LOCATION

When selecting a location to mount the 5107 control panel consider the following factors. The unit should be mounted where it will not be exposed to extremes in temperature and it will be free from moisture. The panel should be accessible to "Main Drop" wiring runs. The 5107 should be located well within secured area but should be accessible for testing and service.

### 2. MOUNT THE 5107

When mounting on interior walls use appropriate screw anchors in plaster. When mounting on concrete, especially when moisture is expected, attach a piece of 3/4 inch plywood to the concrete surface and then attach the 5107. Mount any other desired components (such as optional 7171 modules) to the plywood interface.

### 3. INSTALL THE 9220 POWER TRANSFORMER

Figure 3 shows the connection of the Model 7890 Transient-Surge Protector to the Model 9220 UL Listed Class II Power Transformer (16.5 VAC 45VA). The transformer should be plugged into the 120 VAC 60 Hz. continuous duty (unswitched) grounded outlet mounted to the bottom of the 5107 cabinet as shown in Figure A.

**WARNING:** The Model 9220 contains an internally fused secondary winding. DO NOT SHORT the secondary terminals together when power is applied or the internal fuse will blow. Be sure the shield conductor can not come in contact with the AC output screws.

## 5107 CONTROL PANEL INSTALLATION (CONTINUED)

The Model 7890 Transient-Surge Protector will clamp the AC output of the transformer, reducing transient voltages caused by lightning and other sources. The AC power lines are the most common source of transient/lightning damage in alarm systems. The Model 7890 consists of 2 bi-polar transient suppressors with lugs at its connecting points.

**CAUTION:** Before connecting, verify that the center mounting screw in the AC wall plate, to which the transformer is to be connected, is grounded to earth ground. This can be checked by measuring the AC voltage between the mounting screw and each side of the AC line. There must be approximately 117 VAC between the screw and one side of the outlet, and 0 VAC between the screw and the other side of the outlet. If these voltages are not identical the outlet does not have an earth ground and must be grounded by running an 18 gauge wire from the outlet to a good ground; for example a cold water pipe.

**CAUTION:** To reduce the risk of fire or electrical shock, connect directly to a grounded (3-prong) receptacle.

### 4. CONNECT ALL INITIATING DEVICES AND ACCESSORIES

Connect all initiating devices and accessories to the 5107 terminal strips before connecting AC or DC power to the panel. Use the wiring diagram in Figure 10 and the terminal strip description as a guide.

### 5. CONNECT POWER TO THE 5107

Make sure the EEPROM has been programmed and reinstalled into the 5107 circuit and before continuing (see programming section). Connect the battery cables to the lugs on the backup battery, pay attention to the polarity of the batteries (black to the - terminals, red to the + terminals). Verify that the system is operational before continuing. If system is not operational suspect the backup battery, poor connections or battery polarity. Connect the two conductor cable from the Model 9220 transformer to terminals 1 and 2 on the control panel terminal strip.

**NOTE:** Panel should begin operating as soon as either power source is connected.

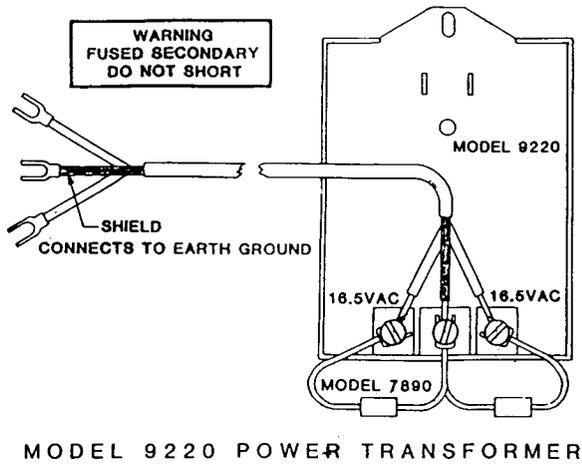

FIGURE 3

ZONE WIRING

1. MODEL 7620 UL LISTED SMOKE DETECTOR

In the following sample wiring diagrams, the Model 7620 listed smoke detector is used. As illustrated in Figure 4, the Black and Red wires of the 7620 are used to provide the +12 VDC input power and the White/Violet and Violet wires provide the normally open alarm contacts. To reset smoke detectors, power must be removed for approximately 2 seconds.

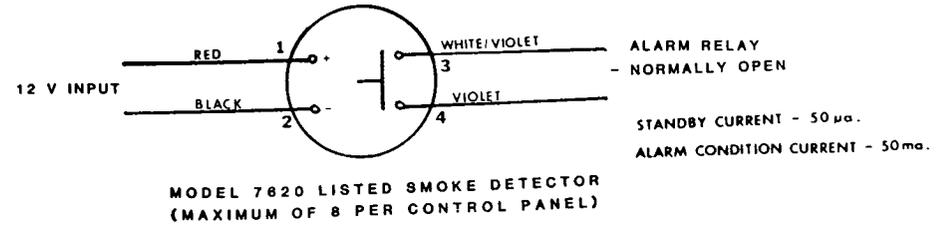

FIGURE 4

2. CLASS A ZONES

Zones 1 and 2 are Class A fire zones. No End-of-Line resistors are needed for these zones. Zone 1 inputs are wired into terminals 10, 11, 12 and 13 as shown in the example in figure 5. Zone 2 inputs are wired into terminals 14, 15, 16, and 17.

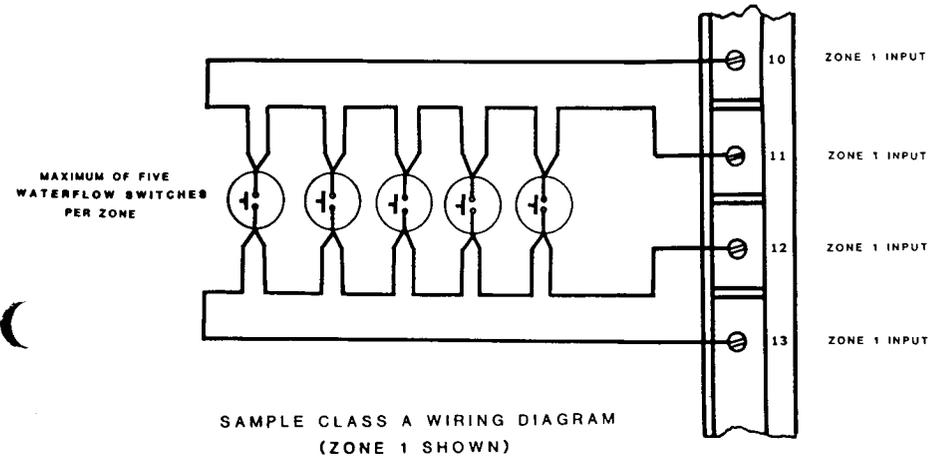

FIGURE 5

### 3. CLASS B ZONES

Zones 3 through 8 are Class B fire zones. One side of each Class B loop will connect to a zone input terminal (see figure 11 for terminal strip designations), and the other side of each loop will connect to loop power smoke detector power. Each Class B loop must employ a Model 7630 15K End-Line resistor wired in series with the loop and in parallel with the Normally Open contacts furthest from the panel. See figure 6 for a sample wiring diagram.

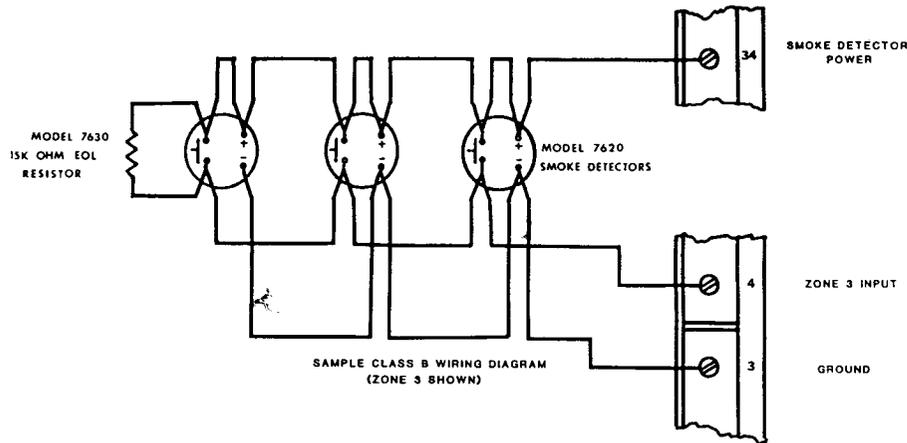

FIGURE 6

### TELEPHONE WIRING

#### 1. DUAL TELEPHONE LINES

The 5107 connects to two separate telephone lines to report data to the central station. An RJ31X type jack should be installed by the telephone company for each line. Two Model 7860 connecting cords will mate to the RJ31X jacks. The opposite end of one of these cords is wired into terminals 29, 30, 31 and 32 of the 5107 and is telephone line #1. The other connecting cord is wired into terminals 25, 26, 27 and 28 of the 5107 and is phone line #2. Refer to Figure 7 and the terminal strip designation for proper installation.

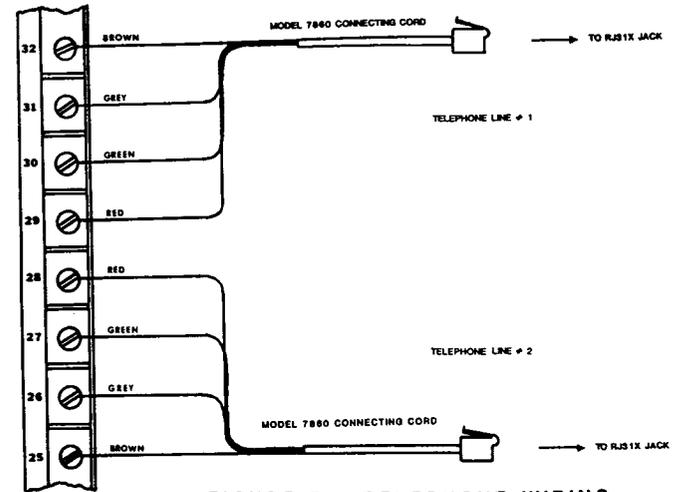

FIGURE 7 - TELEPHONE WIRING

### ACCESSORY WIRING

#### 1. SUPPLEMENTARY ALARM BELL

A 12 VDC supplementary alarm bell may be wired into the 5107 between terminal 24 (bell) and terminal 33 (accessory power). Either a motor driven or a coil driven bell may be used, however, to suppress electrical noise created by the bell you must install the supplied surge protector (Model 7800) directly across the contacts of the bell. To be effective the surge protector must be installed as close to the bell contacts as possible. One UL approved bell is the Wheelock Model 46LG10 12VDC CP. Refer to Figure 8 for wiring. The maximum output load on terminal 24 (Bell) is 350 mA.

#### 2. CONNECTION TO THE MODEL 7171 4-WIRE-LOOP MODULE

Through the use of a Model 7171 module you can convert one of the Class B zones of the 5107 into a Class A zone. One module is required for each additional Class A zone needed. Figure 9 illustrates the proper method of wiring the 7171 module to the 5107 control panel.

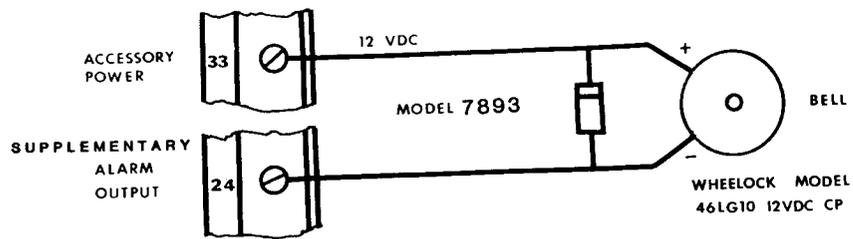

**SUPPLEMENTARY ALARM BELL WIRING**  
**FIGURE 8**

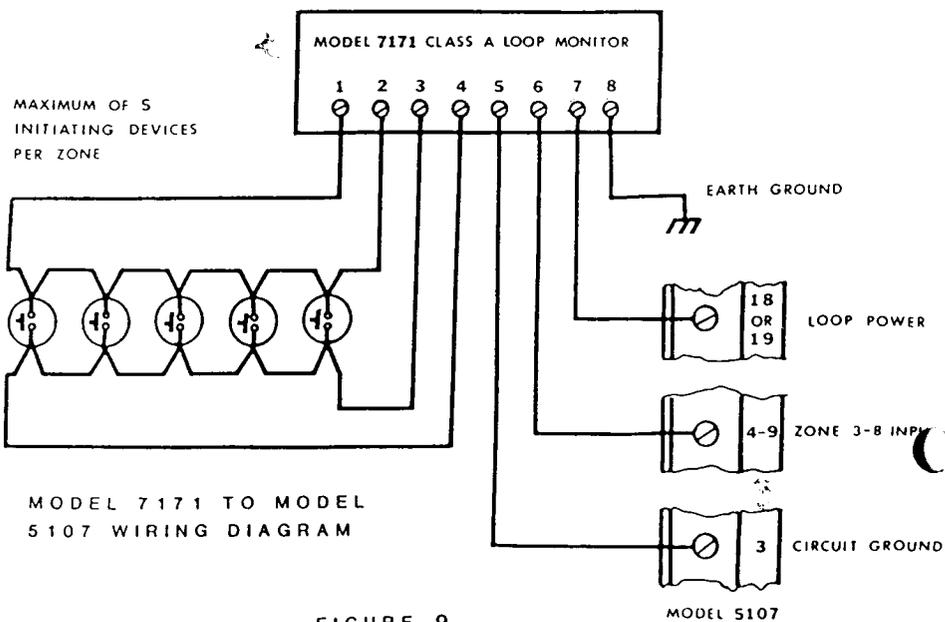

**FIGURE 9**

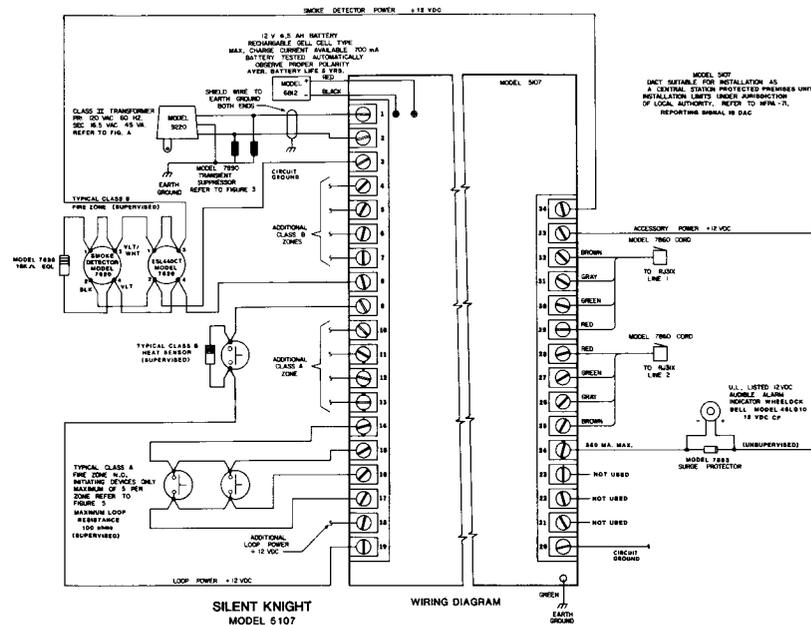

**NOTE:** Referring to Figure 5 and the Wiring Diagram above, the limitation of 5 devices is a National Fire Code limitation for Sprinkler Flow Switches only.

## TERMINAL STRIP DESCRIPTION

### INPUTS

Terminal 1 - 16.5 VAC 60 Hz. (45VA)  
Terminal 2 - 16.5 VAC 60 Hz. (45VA)  
Terminal 3 - Common negative (circuit ground)  
Terminal 4 - Zone 3 input (Class B zone)  
Terminal 5 - Zone 4 input (Class B zone)  
Terminal 6 - Zone 5 input (Class B zone)  
Terminal 7 - Zone 6 input (Class B zone)  
Terminal 8 - Zone 7 input (Class B zone)  
Terminal 9 - Zone 8 input (Class B zone)  
Terminal 10 - Zone 1 input (Class A zone)  
Terminal 11 - Zone 1 input (Class A zone)  
Terminal 12 - Zone 1 input (Class A zone)  
Terminal 13 - Zone 1 input (Class A zone)  
Terminal 14 - Zone 2 input (Class A zone)  
Terminal 15 - Zone 2 input (Class A zone)  
Terminal 16 - Zone 2 input (Class A zone)  
Terminal 17 - Zone 2 input (Class A zone)  
Terminal 18 - Loop power, +12 VDC, 50mA max. (current limited)  
Terminal 19 - Loop power, +12 VDC, 50mA max. (current limited)

A vertical line connects terminals 10 through 17. A horizontal line extends from the middle of this vertical line to the right, ending at the label '\*3'.

### OUTPUTS

Terminal 20 - Circuit Ground  
Terminal 21 - NOT USED  
Terminal 22 - NOT USED  
Terminal 23 - NOT USED  
Terminal 24 - Alarm bell, 350 mA max. 12 VDC.  
Terminal 25 - House line #2 Ring  
Terminal 26 - House line #2 Tip  
Terminal 27 - TELCO #2 RING  
Terminal 28 - TELCO #2 TIP  
Terminal 29 - TELCO #1 TIP  
Terminal 30 - TELCO #1 RING  
Terminal 31 - House line #1 Tip  
Terminal 32 - House line #1 Ring  
Terminal 33 - Accessory power, +12 VDC, 1.2A max \*1 (fused at 1.5A)  
Terminal 34 - Smoke detector power, +12 VDC, 0.4A max (fused at 0.5A) \*2

\*1 NOTE: The sum of the current ratings of all 12V accessories connected to terminal 33 must not exceed 1.2A.

\*2 NOTE: The maximum number of smoke detectors per panel is 8.

\*3 NOTE: The maximum loop impedance is 100 ohms. (Not including EOL resistor)

\*4 NOTE: If (N) is selected in step 6.3 and either phone number reports in the Radionics format, then zones 6,7 and 8 CANNOT be used for alarm reporting. Instead, low AC will report as zone 6, the phone lines will report as zone 7, and earth ground fault will report as zone 8.

## TRANSIENT VOLTAGE PROTECTION

The Model 5107 Control Panel is protected from transient voltage damage due to lightning or static electricity, in several ways.

1. AC INPUT PROTECTION - Fast acting "Tranzorbs" (Model 7890) connected between each side of the Class II transformer and earth ground (Refer to Figure 3). MOV (Metal Oxide Varistor) protection between each side of the AC input and earth ground.
2. TELEPHONE CIRCUIT PROTECTION - MOV (Metal Oxide Varistor) protection between TIP RING and earth ground. Line seizure relays provide an air gap between the 5107's internal circuitry and phone lines.
3. LOOP INPUT PROTECTION - Fast acting zener diode protection from all Class B loop inputs to ground. Class A loop inputs are isolated from internal circuitry by opto-isolators.
4. SYSTEM PROTECTION BY DESIGN - The Model 5107 circuit board layout isolates vulnerable components from known transient sources.

### EARTH GROUND

The key to any good transient protection plan is making the proper earth ground connection to all protection devices. Failure to use all of the recommended protection devices will jeopardize the effectiveness of the protection plan.

Finding a good earth ground is always the first step. Connecting to a water pipe may not always provide an earth ground. Check for PVC (plastic) pipe. Electrical ground may not be at a true earth ground potential. Old and/or poor ground connections in the electrical system may allow electrical ground to float at some potential above earth ground. Be observant when selecting your ground source. When in doubt, a grounding rod should be driven into moist earth and used as the earth ground source.

### 5107 EARTH GROUND CONNECTIONS

Connect the common lead of the Model 7890 protection device to earth ground (via shielded two-conductor cable and ground pin of the Class II transformer as shown in figure 3)

NOTE: Never connect the system circuit ground to earth ground.

### LIGHTNING PROTECTION

As with any electronic equipment, precautions should be taken when installing the 5107 to protect against high energy transients which can be generated by lightning. The following steps, if observed, will provide the maximum protection against these transients.

1) Insure that the AC outlet that you intend to use for the Model 9221 transformer has a "good" connection to earth ground. This can be done at the outlet, using a digital volt meter, by measuring the AC voltage between the "hot" side of the outlet and neutral, then comparing that voltage to the voltage reading made between the "hot" side and the ground connection. The difference between these two readings should not exceed .2 VAC.

2) Verify at the breaker or fuse box, that there is a ground wire from the neutral buss bar in the box, to the main cold water pipe at a point closest to where the pipe enters the building. If there is a water meter at this point, be sure that the ground wire is bonded to the pipe on both sides of the meter.

**CAUTION:** In newer construction the water supply pipe may be plastic. If this is the case, check to see if the breaker box has been bonded to a ground rod. If not, an electrician should be called and a ground rod should be driven into a moist area close to the building and bonded to the breaker box.

3) Verify that the neutral buss block in the breaker or fuse box, has a bonding screw connecting it to the box itself.

#### MODEL 5107 UL INSTALLATION ADDENDUM

The Model 5107 has been UL listed as a Control/Communicator for use in a central station fire alarm system under NFPA 71. Copies of NFPA 71 may be obtained by writing to:

National Fire Protection Association  
Battery March Park  
Quincy, MA 02269

In any installation which is to be submitted for certification you must use UL listed equipment, properly installed by professionals in compliance with the above standards and the National Electrical Code (NFPA 70). The installation must also meet requirements of local authorities. The 5107 must report to a Certified Central Station and the Central Station Company or the Installation Company must provide routine testing and maintenance of the system to insure continued operation in compliance with the requirements.